



TEACHING LAB MOTOR DYNO KIT

Consisting of a base with a PM generator load & three flange mounted test motors

200 Watt Brushless DC DYNO MOTOR

(All data taken from original PC-BDC design simulations)

Number of Poles	= 10
Rated Voltage	= 42 VDC
Rated Power	= 200 W
Rated Speed	= 3600 rpm
Rated Torque	= 4.7 Lb-In
Rated Current	= 5 Arms/phase
Rated efficiency	= 90%
No Load Speed	= 4700 rpm @ 42 VDC
Motor Constants	
Kt	= 0.72 Lb-In/A
Ke	= 9.83 V/Krpm
Res @ 20 deg C	= 0.15 Ohms +/- 10% L-L
Inductance	= 433 mh L-L
Encoder connector has 8 pins for A,B, Index, +5VDC, GRN and Three hall outputs U,V,W for commutation.	

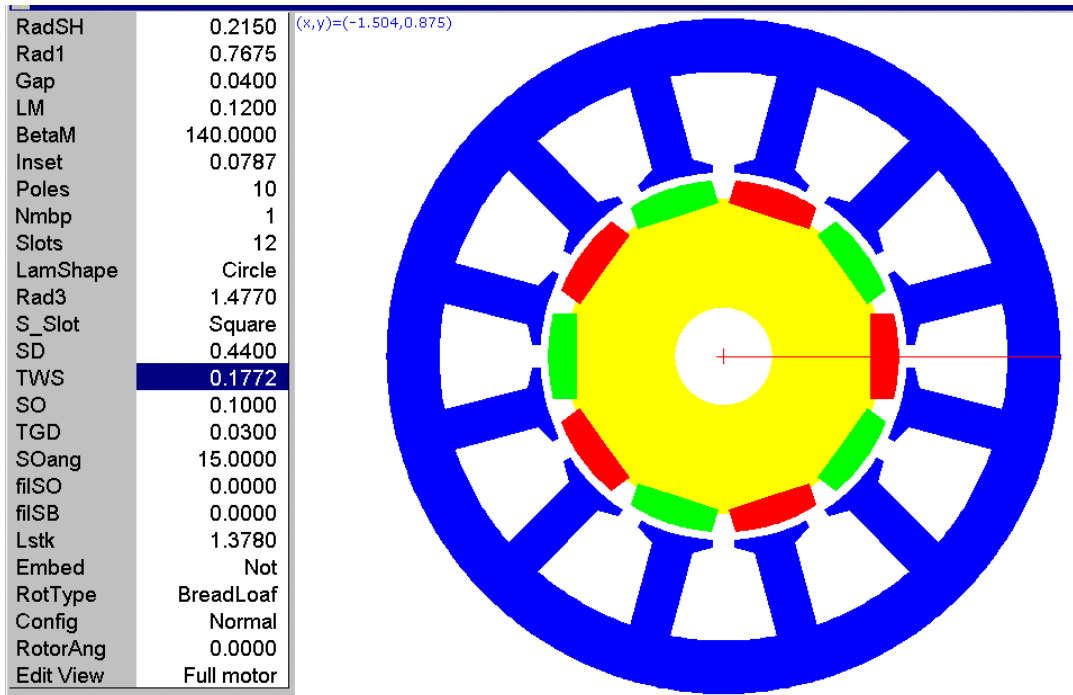

Cross section of stator lamination and rotor of the 10 pole AC synchronous brushless PM motor

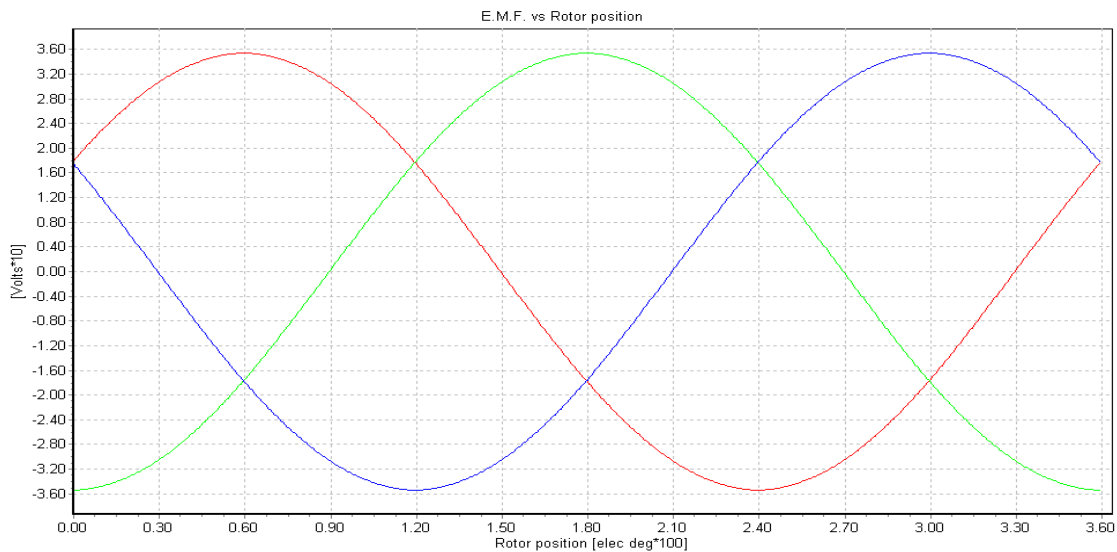

Phase Back Emf @ 3600 rpm

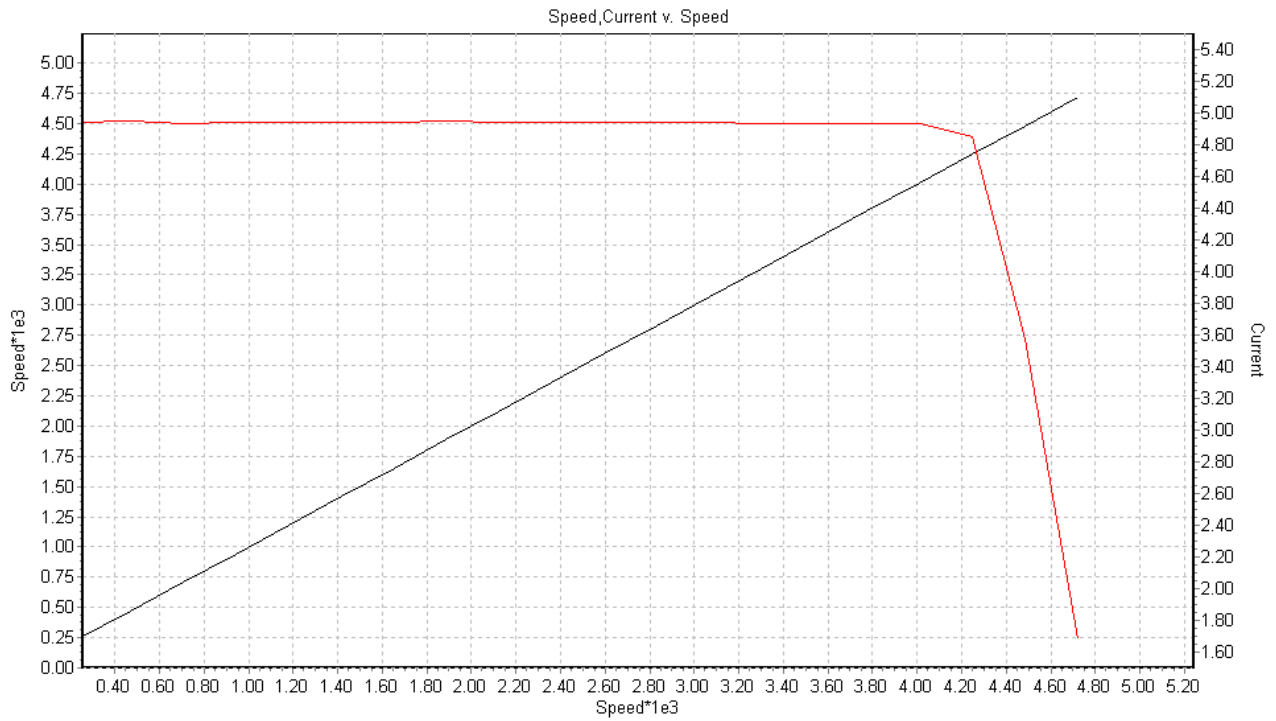

Torque & Phase Current vs Speed Plot @ 42 VDC & 5 Aphase limit

200 Watt Three Phase AC Induction Motor for DYNO
 (All data taken from original PC-BDC design simulations)

Number of Poles = 4
Rated Power = 200 W
Rated Voltage = 30 VAC (42 VDC Buss to Inverter)
Rated Speed = 3621 rpm 128 HZ & 5.7% slip
Rated Torque = 4.67 Lb-In
Rated efficiency = 79.6%
No Load Speed = 3600 rpm @ 120Hz
Res @ 20 deg C = 0.34 Ohms +/- 10% L-L
Encoder connector has 5 pins for A, B, Index, +5VDC & GRN

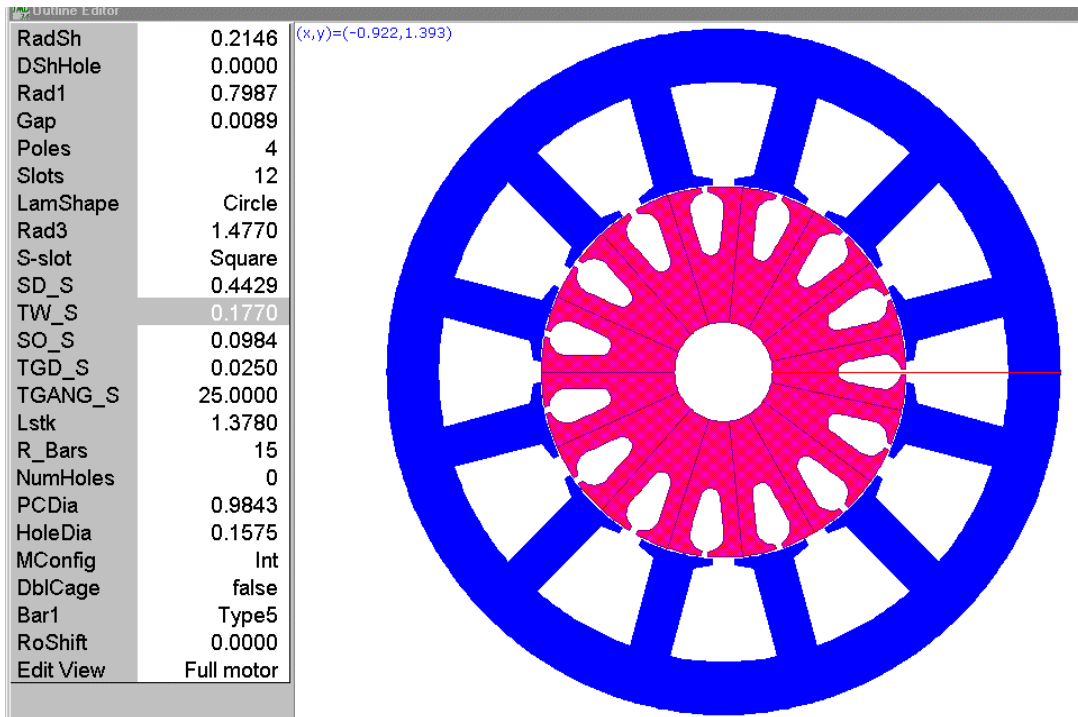

Cross Section of Rotor & Stator for 4 pole three phase AC induction motor
For use with constant V/Hz drive or a Flux vector Drive

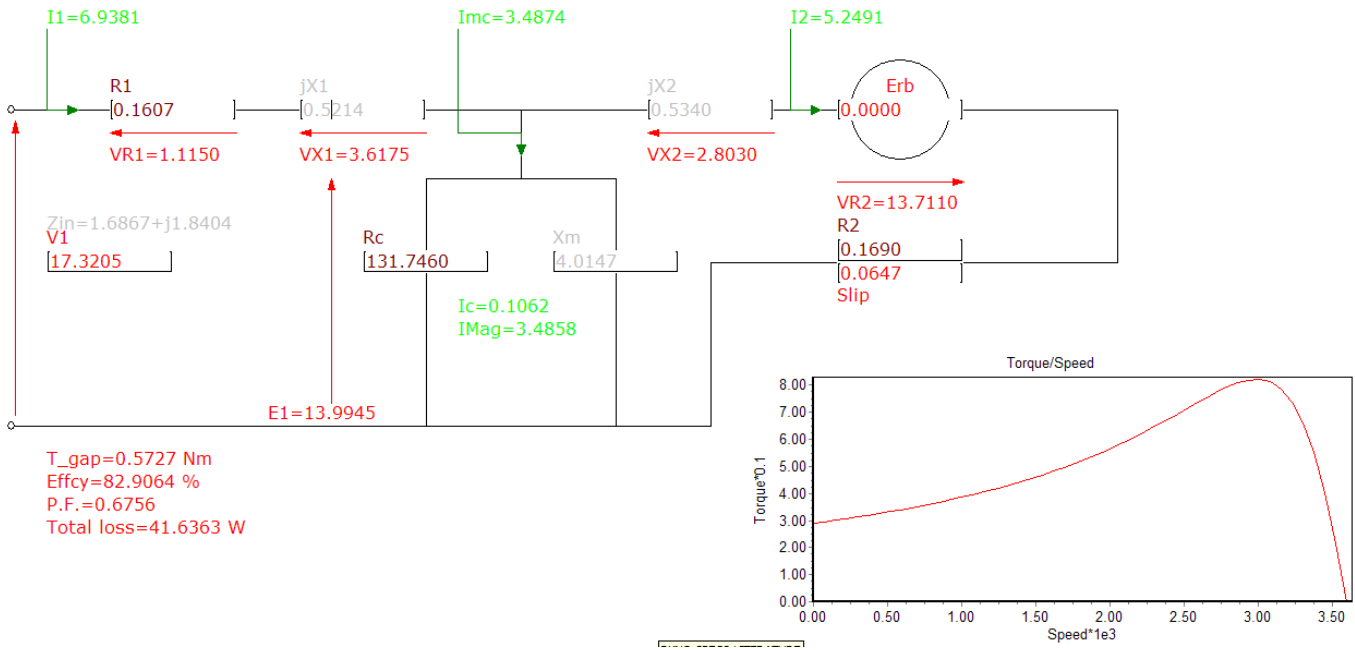

Equivalent Circuit MODEL

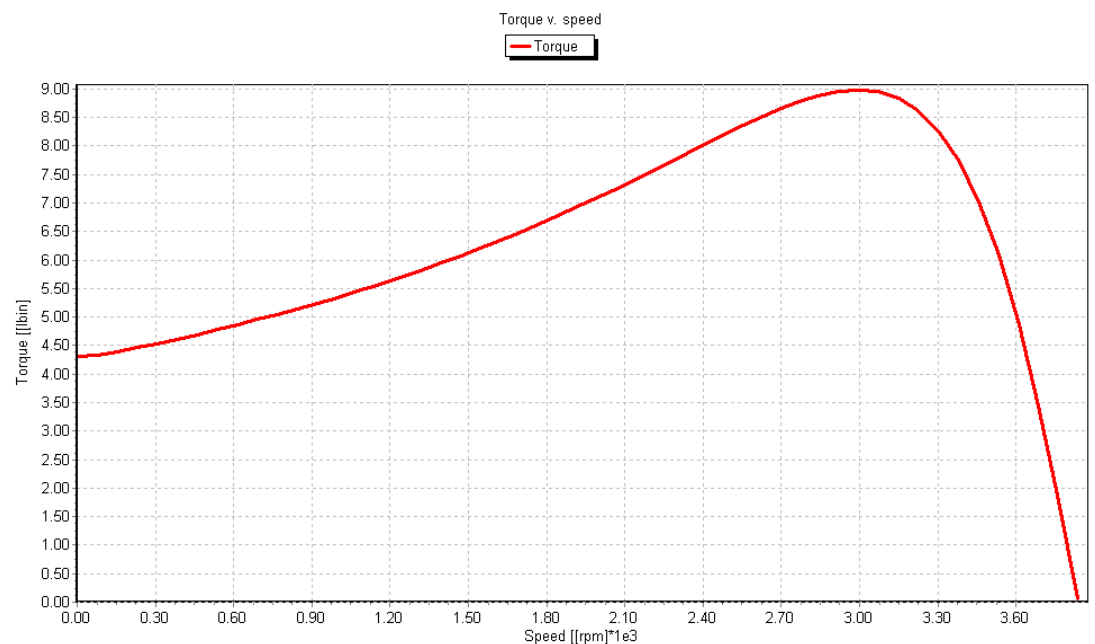

**Torque vs Speed Curve
(31 VAC & 130 HZ)**

Both the PMDC generator and the PMDC motor are the same component. Rated at 42 VDC, Max speed = 4 Krpm, Arm Res. (av. incl. brushes and leads) = 0.59Ω
 $K_e = 7.51 \text{ V/Krpm}$, $K_t = 0.074 \text{ Nm/A}$, 250 Watts rated output, 350 W peak for 20 sec.
Generator encoder connector has 5 pins for A, B, Index, +5VDC & GRN
PM-DC motor is not equipped with an encoder.

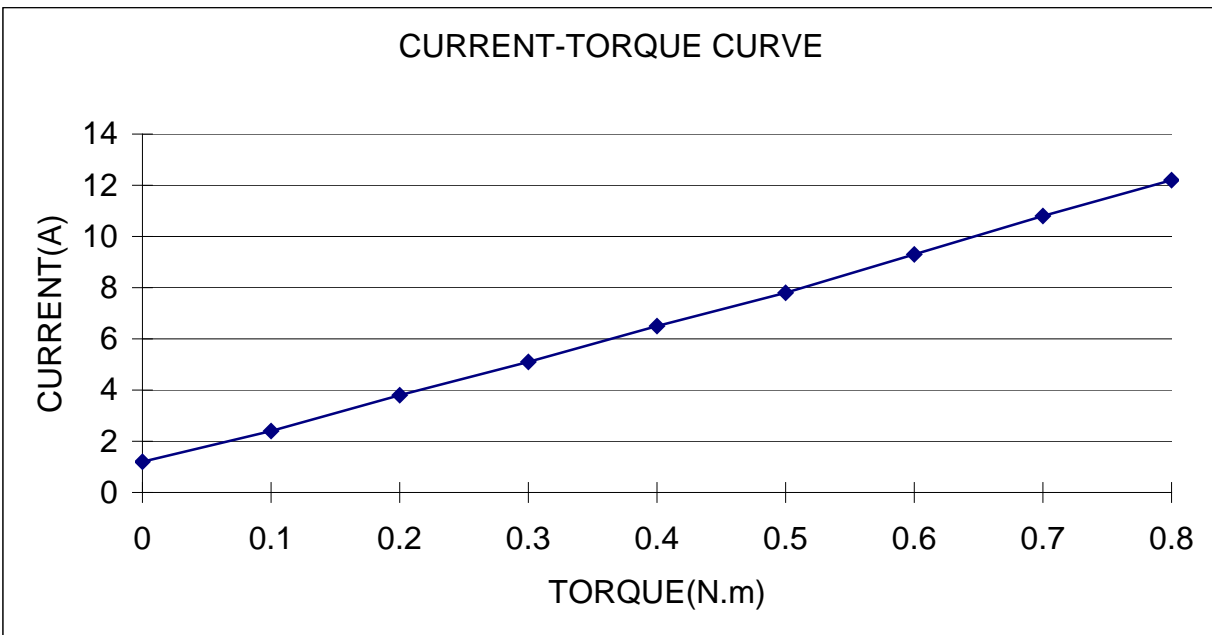
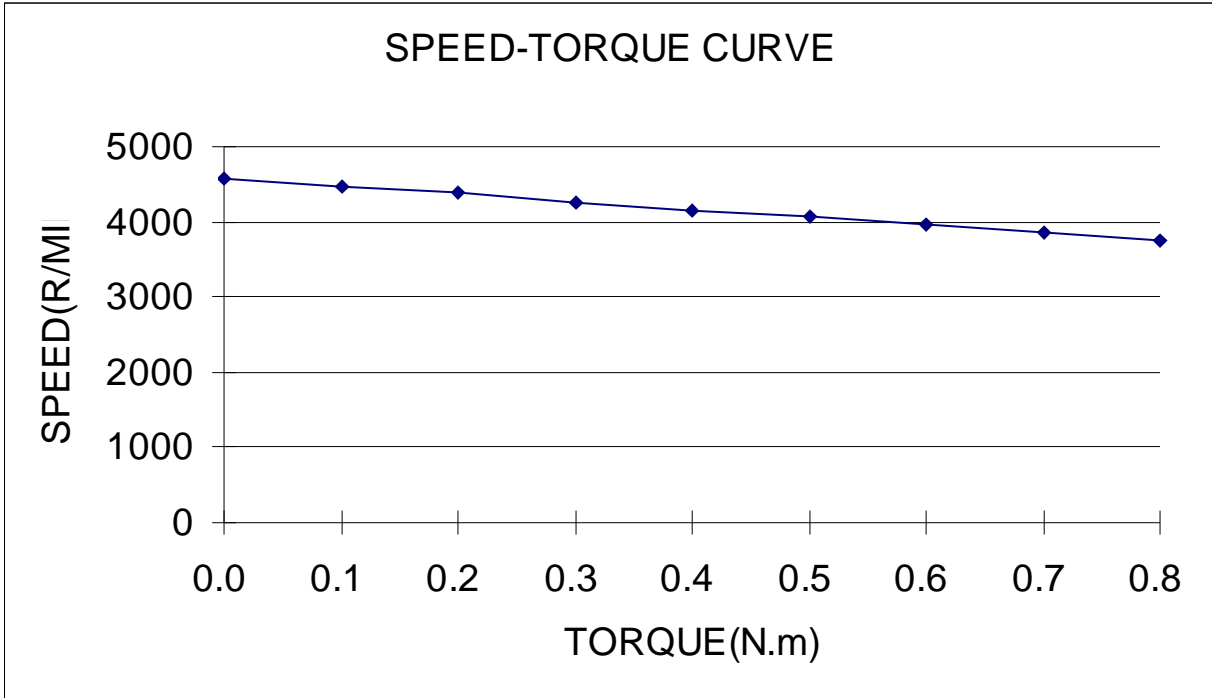

POWER.EFF-SPEED CURVE

